

Condenser to Evaporator Line

Material

| Item | Specification |
|--|---------------|
| Motorcraft® PAG Refrigerant Compressor Oil YN-12-D | WSH-M1C231-B |

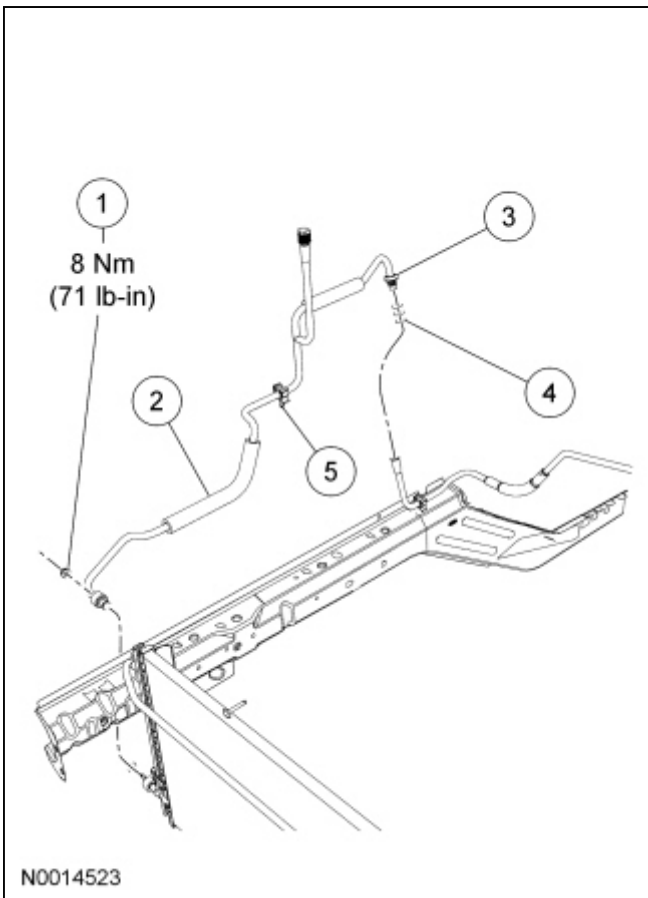

| Item | Part Number | Description |
|------|-------------|---|
| 1 | W520413 | Condenser outlet fitting nut |
| 2 | 19835 | Condenser-to-evaporator line |
| 3 | — | Evaporator inlet line fitting (part of 19835) |
| 4 | 19E889 | O-ring seal (4 required) |
| 5 | 9F274 | Condenser-to-evaporator line clip |

Removal and Installation

1. Recover the refrigerant. For additional information, refer to [Section 412-00](#).
2. With the vehicle in NEUTRAL, position it on a hoist. For additional information, refer to [Section 100-02](#).
3. Disconnect the evaporator inlet line fitting.
 - Discard the O-ring seal.

4. Detach the condenser-to-evaporator line clip.
 5. Remove the condenser outlet fitting nut and disconnect the fitting.
 - Discard the O-ring seal.
 - To install, tighten to 8 Nm (71 lb-in).
 6. Remove the condenser-to-evaporator line.
 7. To install, reverse the removal procedure.
 - Install new O-ring seals.
 - Lubricate the refrigerant system with the correct amount of clean PAG oil. For additional information, refer to [Section 412-00](#).
 8. Evacuate, leak test and charge the refrigerant system. For additional information, refer to [Section 412-00](#).
-